

NXCT-F3 Flexible Optical Current Sensor



The NxtPhase Flexible Optical Current Sensor has a flexible fiber optic sensing loop that is easy to wrap around high-voltage bushings, generator buses, or other conductors in ways not possible with conventional CTs. The sensing loop is an in-line, all-dielectric cable, which connects to standard NXCT electronics giving the user the same high performance capability and output options as the high-voltage NXCT. It is the ideal solution for installation in difficult spaces on a temporary or permanent basis.

Flexible Form Factor

The NXCT-F3 features a linear wrap-around sensing head that can be installed without breaking the current path. Current measurement does not depend on sensor position; all that is required is a whole number of turns around the conductor with the sensor loop end plugged back into its enclosure.

High Performance

The NXCT-F3 is a precision optical sensor available in a variety of measurement and protection accuracy classes over a wide temperature range.

Lightweight Fiber Optic Design

The all dielectric sensing head is easy to install and set up even on a temporary basis for calibration of another CT or optical sensor. A generous 20 meter sensor length allows the user to configure the sensor through conduit or other supports while maintaining strike distance and safety requirements mandated for the system voltage and application. Longer head lengths are available as an option.

Software Adjustable Scale Factor

The scale factor, or electronic turns ratio, can be adjusted in software allowing a single sensor to address a broad range of primary currents as it is deployed in the field or moved from job to job. Furthermore, the user can adjust the sensitivity of the sensor by selecting the number of fiber turns around the conductor – more turns for small currents, fewer turns for large primary currents.

NXCT-F3

Specifications

Sensor Mechanical

Sensing Cable Construction	All dielectric fiber optic cable
Sensing Cable Length	20 m standard; contact factory for other lengths
Sensing Cable Diameter	7 mm
Minimum Bend Radius	100 mm
Interconnect Cable Length	up to 400m
Optical Modulator Enclosure	15.3" x 13.3" x 6.7" (389 mm x 338 mm x 170 mm)
Sensor Electronics Dimensions	19" x 18" x 5.25" (483 mm x 457 mm x 133 mm)
Optional High Energy Analog Amplifier Module	19" x 18" x 3.5" (483 mm x 457 mm x 89 mm)

Environmental

Operating Temperature Range (sensor and modulator)	-40°C to 60°C (-40°F to 140°F) Outdoor Service Conditions
Opto-Electronics Module	-5°C to 40°C (23°F to 104°F) Indoor Service Conditions
Seismic Capability	0.5 g

Electronics

Packaged in 2 modules:



Sensor Electronics



Current Amplifier/Power Supply

Low Energy Analog Interfaces ¹ : (standard)	4 V_{rms} metering 200 mV _{rms} protection
Bandwidth	0.5 Hz to 6 kHz
High Energy Analog Interfaces ¹ : (optional)	1 A_{rms} or 5 A_{rms} nominal, B-0.1 (2.5 VA) burden at power factor 0.9 for metering
Bandwidth	10 Hz to 6 kHz
Input Power Requirements	70 V_{dc} to 150 V_{dc} Typical power 50 W
Electronic Turns Ratio	User selectable
Alarms Contacts	Data invalid Maintenance required

Electrical Performance

Maximum Continuous Current	100,000 A_{rms} / number of fiber turns
Rated Current	100 A – 100 kA ²
Available Measurement Accuracy Classes	IEEE 0.3 IEC 0.2, 0.2s
Available Protection Accuracy Classes	IEEE 10% IEC 5P 5TPE (low energy analog)

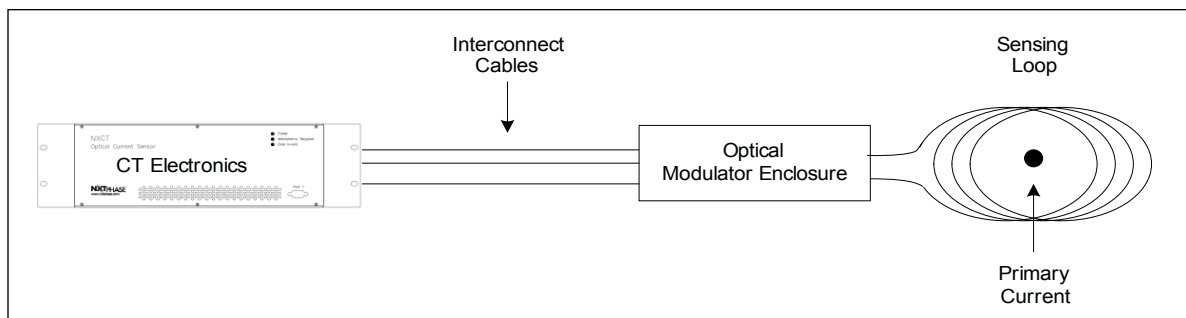

¹ Scales linearly with primary voltage and current.

² Contact factory with your application details to determine optimal set-up of the sensor.